

Fluidseal

HIGH PERFORMANCE MOBILE EQUIPMENT KITS



www.sealsonline.com

HIGH PERFORMANCE MOBILE EQUIPMENT KITS

Typical cylinder layout

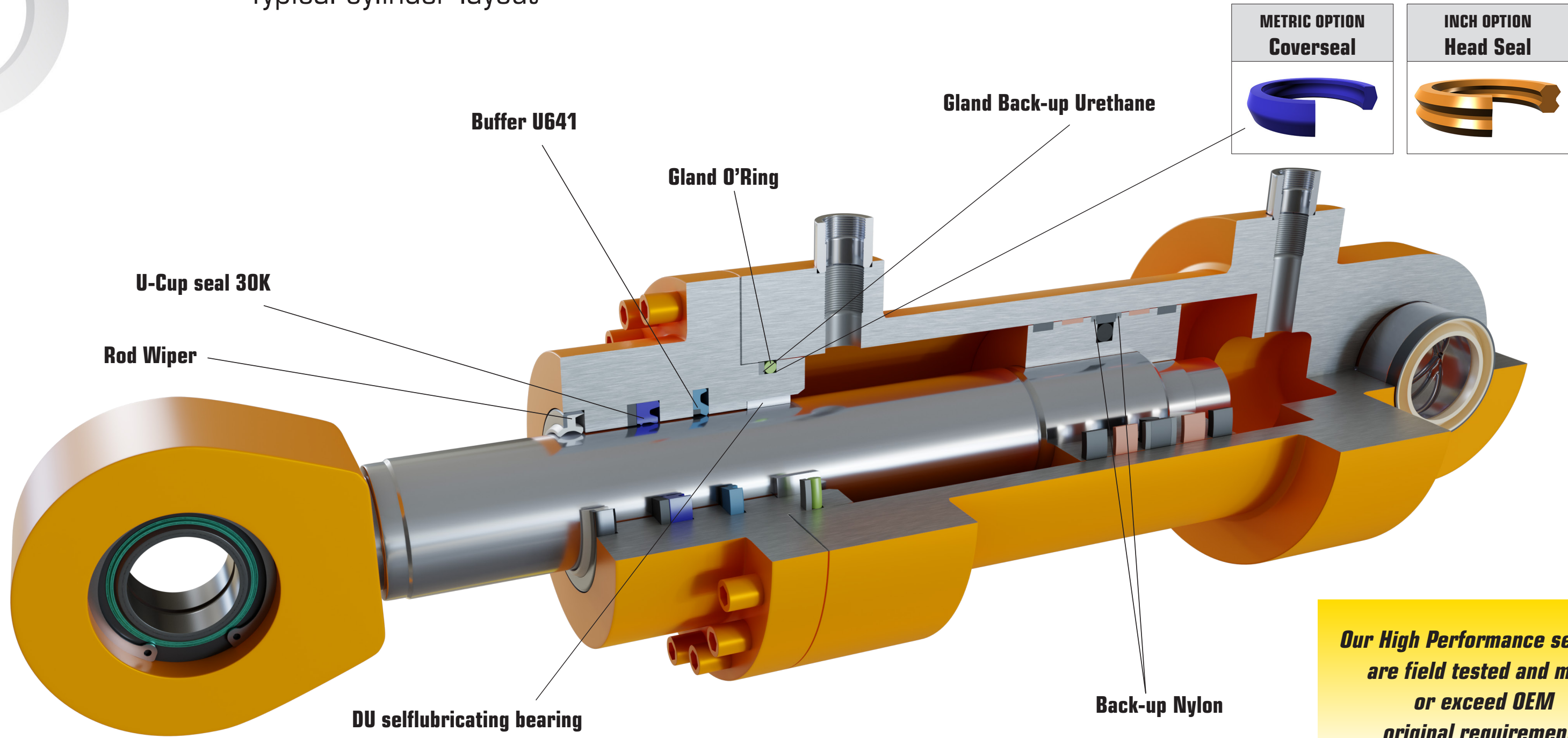



Our High Performance seal kits are field tested and meet or exceed OEM original requirements.

HIGH PERFORMANCE MOBILE EQUIPMENT KITS

	Buffer U641	
Problems	Hydrolysis, heat aging, compression set against bio fuels.	
Solutions	Change to Freudenberg's premium U641 buffer material.	
Benefits	High extrusion resistance allows operating pressure of 41 MPa/6000 PSI Improved stability in temperatures up to 230 °F/110 °C = improved compression set. Outstandingly suited for mineral and biodegradable hydraulics fluids.	

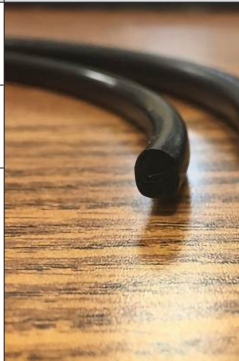
	Secondary U-Cup seal	
Problems	Hydrolysis, heat aging, compression set against bio fuels.	
Solutions	Change to Freudenberg's 30K U-cup seal with double lip.	
Benefits	Improved double lip profile adds heel stabilizing lip and increased oil retention to the rod for lower friction. Higher extrusion limits allows operating pressures of 50 MPa/7250 PSI. Improved stability in temperatures from -31 °F to 250 °F/-35 °C to 120 °C = improved compression set. Outstandingly suited for mineral and biodegradable hydraulics fluids. Hydrolysis resistant.	

	Gland O'Ring	
Problems	Heat aging and compression set. O'ring conforms to groove.	
Solutions	Move to "Specially Formulated" and lab tested low compression set material.	
Benefits	Improved stability in temperatures from -22 °F to 300 °F/-30 °C to 150 °C. Increased resistance to compression set. Excellent abrasion resistance. Superior fluid resistance.	

	Urethane Gland Back-up	
Problems	Extruding under pressure and breathing.	
Solutions	Move to specially formulated shore D material to improve extrusion resistance.	
Benefits	Increased pressure resistance using 60 shore D.	

	Coverseal PU 83 or Head Seal	
Problems	"Shock Loading"	
Solutions	Move to cover seal or head seal profile.	
Benefits	Improved sealing function at low and high pressure conditions. Minimal deformation, even at a high pressure. Very high extrusion resistance. Very low compression-set. Easy installation, no twisting. For use in standard grooves. Available in various compounds.	

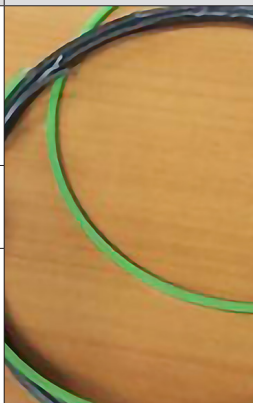
	Back-up Nylon	
Problems	Current thermoplastic 3mm x 3mm anti-extrusion rings (market knows them as green) are extruding and blowing out under pressure spikes/shock loading.	
Solutions	Move to high tensile strength filled nylon with internally lubricated additives.	
Benefits	Increased extrusion resistance by using nylon with strength filler. Increased heat resistance up to 440 °F/240 °C. Increased media compatibility. Machine finished for tight tolerances.	

HIGH PERFORMANCE MOBILE EQUIPMENT KITS

Additional parts available

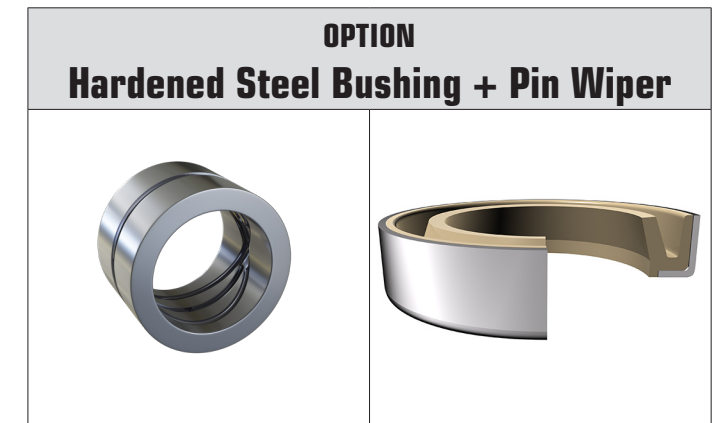
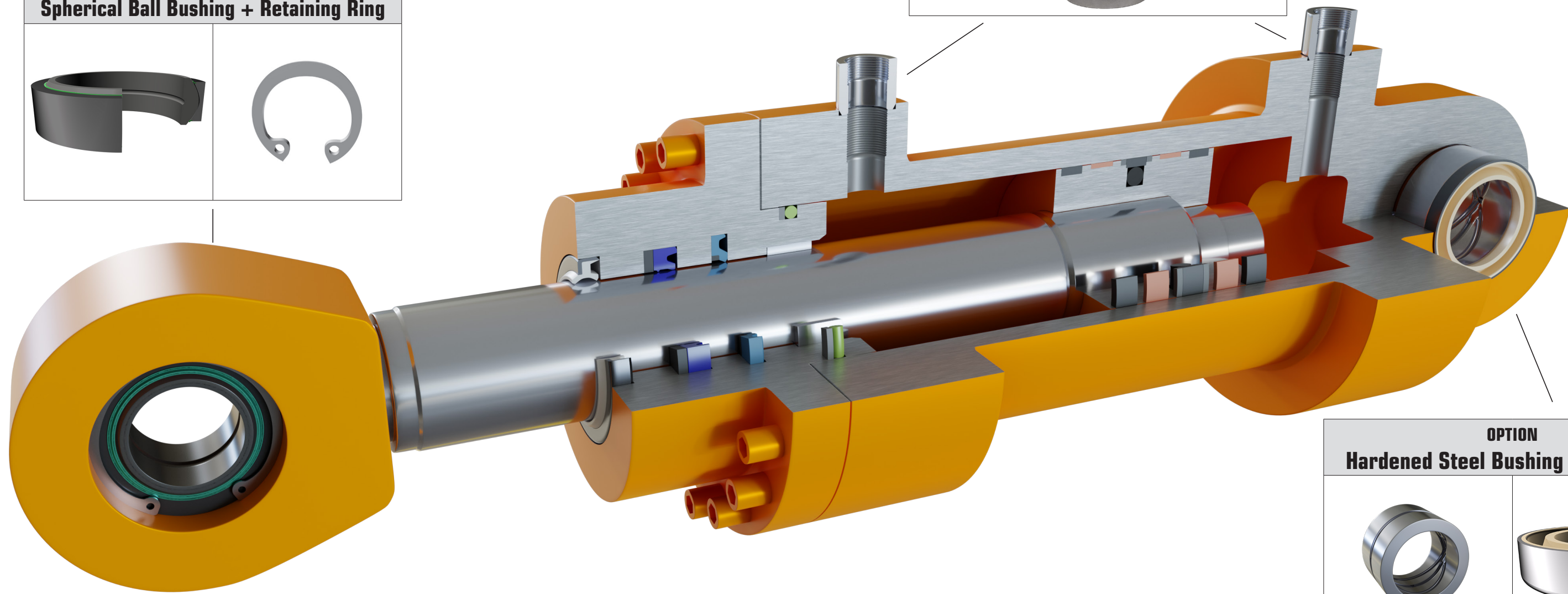
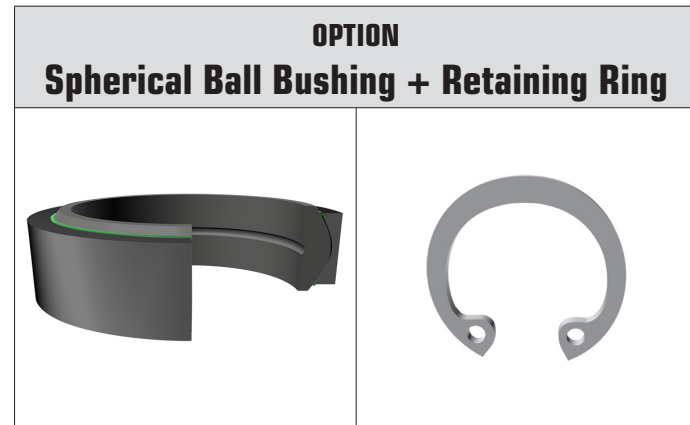

FLUIDSEAL EXPRESS

MACHINING CENTER

Precision – Quality – Quick Turnaround

Our FLUIDSEAL EXPRESS rapid cell machining center offers you custom made solutions. Our CNC turn centers are able to offer you complex sealing solutions of both high precision and quick turnaround time, manufactured from state-of-the-art materials. Regardless of your industry or your application, we will strive to assist you in both design and production of high performance seals in a speedy time frame.

Materials

- AFLAS®
- DYNAMAX®
- EPDM
- FPM – FKM
- HNBR
- NBR
- NYLON
- PEEK
- POLYURETHANE
- SILICONE
- TEFLON®
- UHMW
- CUSTOM BLENDS



Full range of materials available for FDA applications

EXCLUSIVE

NEW POLYURETHANE
GENERATION
94 AU 30000

FREUDENBERG-NOK
INNOVATING TOGETHER



Contact us for more information!

OTHER SERVICES

- ✓ Custom packaging/labeling
- ✓ Cut gaskets
- ✓ Engineering and technical assistance
- ✓ On site training seminars
- ✓ Precision split Clipper shaft seals
- ✓ Vulcanizing